



60W

REVERSIBLE MOTOR □ 90mm LEAD WIRE TYPE

SIZE mm sq.	Type	Poles	Output (W)	Voltage (V)	Frequency (Hz)	Duty	Rated Load				Starting Torque		Capacitor (uF)
							Current (A)	Speed (rpm)	Torque (kg-cm) (N-m)		(kg-cm)	(N-m)	
90	S9R60GA() S9R60GA()(TP) S9R60GA()CE	4	60	1 ∅ 110	60	30min.	1.60	1600	3.80	0.380	7.00	0.700	25.0
	S9R60GB() S9R60GB()(TP) S9R60GB()CE	4	60	1 ∅ 220	60	30min.	0.75	1600	3.80	0.380	7.00	0.700	6.0
	S9R60GC() S9R60GC()(TP) S9R60GC()CE	4	60	1 ∅ 100	50	30min.	1.40	1250	4.80	0.480	6.00	0.600	25.0
	60				1.60		1550	3.90	0.390				
	S9R60GD() S9R60GD()(TP) S9R60GD()CE	4	60	1 ∅ 200	50	30min.	0.70	1250	4.80	0.480	5.50	0.550	6.0
	60				0.76		1550	3.90	0.390				
	S9R60GE() S9R60GE()CE	4	60	1 ∅ 100	50	30min.	1.40	1250	4.80	0.480	5.90	0.590	25.0
	60				1.60		1550	3.90	0.390				
	60				1.30		1600	3.90	0.390	6.00			
	S9R60GX() S9R60GX()CE	4	60	1 ∅ 220	50	30min.	0.63	1250	4.80	0.480	5.90	0.590	5.0
	1 ∅ 240			0.67			5.00		0.500	6.30	0.630		

- ❖ S9R60GE is UL approved (UL FILE No. E172720) thermally protected type.
- ❖ Appropriate capacitors shall be used according to the voltage for S9R60GE type since the size of the capacitor differs by different voltages. Malfunction may occur when not used properly. Capacitor for 115V will be delivered otherwise the required voltage is informed.
- ❖ CE marked at the end of model name indicates that it is thermally protected type which has received CE with built-in TP. S9R60GE()CE is available only for 115V specification.
- ❖ TP marked at the end of the model name indicates that it is standard motor with Thermal Protector mounted. S9R60GE, S9R60GX is thermally protected type with TP mounted.
- ❖ Data is measured with friction brake mounted.
- ❖ () is for marking 'L' type or 'H'. 'L' should be used with gearhead 'L' and 'H' should be used with gearhead 'H'.

50Hz

GEAR RATIO		3	3.6	5	6	7.5	9	10	12.5	15	18	20	25	30	36	40	50	60	75	90	100	120	150	180	200
MODEL	rpm	500	416	300	250	200	166	150	120	100	83	75	60	50	41	37	30	25	20	16	15	12	10	8	7.5
S9KC□()	kg-cm	12.2	14.6	20.3	24.3	30.4	36.5	40.5	45.6	54.8	65.7	73.0	82.5	99.0	119	132	165	198	200	200	200	200	200	200	200
S9KC□()-S	Nm	1.196	1.431	1.989	2.381	2.989	3.577	3.969	4.469	5.370	6.439	7.154	8.085	9.702	11.66	12.94	16.17	19.40	19.60	19.60	19.60	19.60	19.60	19.60	19.60

60Hz

GEAR RATIO		3	3.6	5	6	7.5	9	10	12.5	15	18	20	25	30	36	40	50	60	75	90	100	120	150	180	200
MODEL	rpm	600	500	360	300	240	200	180	144	120	100	90	72	60	50	45	36	30	24	20	18	15	12	10	9
S9KC□()	kg-cm	9.72	11.7	16.2	19.4	24.3	29.2	32.4	36.5	43.8	52.6	58.4	66.0	79.2	95.0	106	132	158	177	200	200	200	200	200	200
S9KC□()-S	Nm	0.953	1.147	1.588	1.901	2.381	2.862	3.175	3.577	4.292	5.155	5.723	6.468	7.762	9.310	10.39	12.94	15.48	17.35	19.60	19.60	19.60	19.60	19.60	19.60

- ❖ The code in□ of gearhead model is for gear ratio.
- ❖ It is the permissible torque of the assembled motor and gearhead.
- ❖ The permissible torque of the motor and inter-decimal gearhead is 200 kg-cm.
- ❖ ■ color indicates that the output shaft of the geared motor rotates in the same direction as the output shaft of the motor. Others indicate rotation in the opposite direction.
- ❖ Rpm is based on synchronous speed (50Hz: 1500rpm, 60Hz: 1800rpm) divided by gear ratio. The actual rotation speed can be 2~20% less than displayed value depending on the load.
- ❖ () is for marking 'L' type or 'H'. 'L' should be used with motor 'L' and 'H' should be used with motor 'H'.

DIMENSIONS

+ GEARED MOTOR

* MOTOR MODEL : S9R60□□
 * HEAD MODEL : S9□C3B□-S~S9□C200B□-S

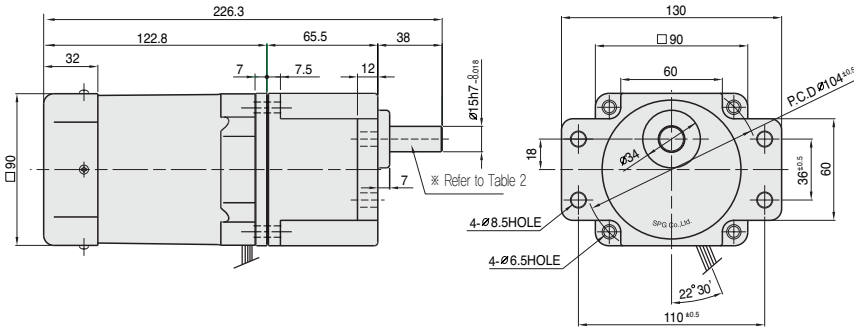

* HEAD MODEL : S9□C3B□~S9□C200B□

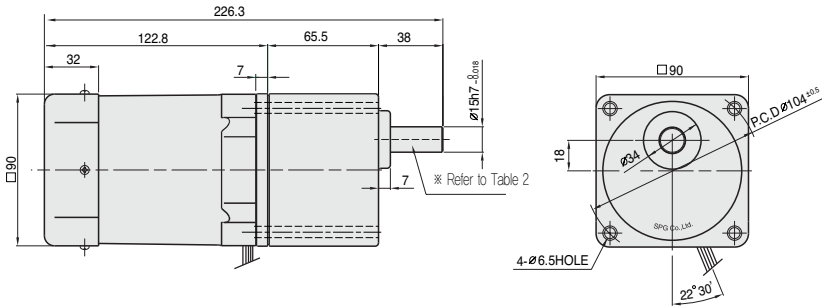

+ MOTOR

* MOTOR MODEL : S9R60□□□

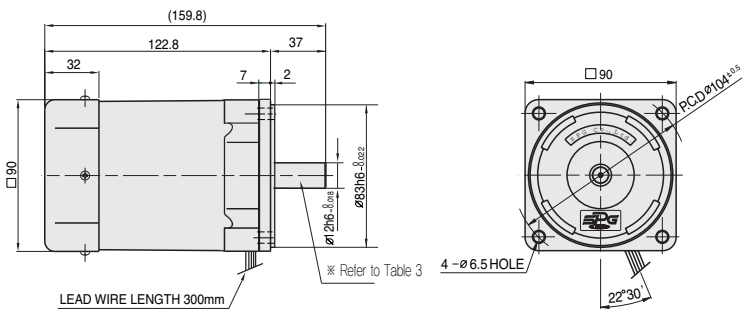

+ INTER-DECIMAL GEAR HEAD

* MODEL : S9GX10B(H,L)-S

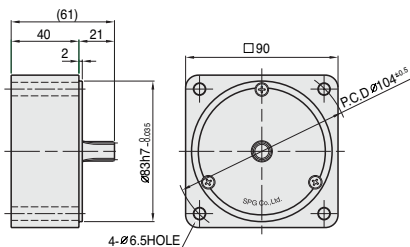

+ WEIGHT - (Table 1)

PART	WEIGHT(kg)	
MOTOR	2.48	
DECIMAL GEAR HEAD	0.65	
GEAR HEAD	S9□C3B□ ~S9□C10B□	1.21
	S9□C12.5B□ ~S9□C20B□	1.30
	S9□C25B□ ~S9□C60B□	1.40
	S9□C75B□ ~S9□C200B□	1.45

+ KEY SPEC

GEAR HEAD	MOTOR

+ SPEC for output shaft of gearhead - (Table 2)

MODEL	TYPES OF OUTPUT SHAFT
STRAIGHT TYPE	
S9SC3B□ ~S9SC200B□	
D-CUT TYPE	
S9DC3B□ ~S9DC200B□	
KEY TYPE	
S9KC3B□ ~S9KC200B□	

+ SPEC for output shaft of motor - (Table 3)

MODEL	TYPES OF OUTPUT SHAFT
GEAR TYPE	
S9R60G□□	
STRAIGHT TYPE	
S9R60S□	
D-CUT TYPE	
S9R60D□	
KEY TYPE	
S9R60□	

DIMENSIONS

+ GEARED MOTOR

※ MOTOR MODEL : S9R60G□H
 ※ HEAD MODEL: S9□D3B~S9□D200B

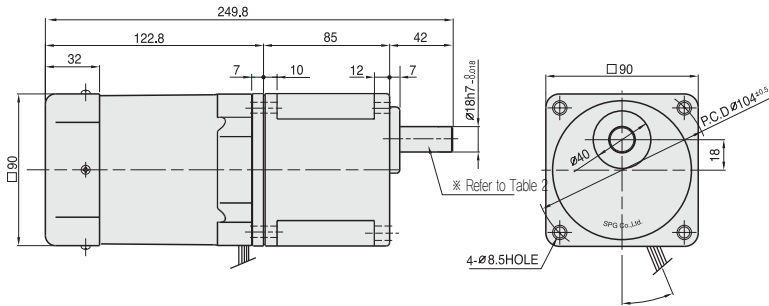

+ WEIGHT - (Table1)

PART		WEIGHT(kg)
MOTOR		2.48
GEAR HEAD	S9□D3B ~S9□D10B	1.65
	S9□D12.5B ~S9□D20B	1.80
	S9□D25B ~S9□D60B	1.90
	S9□D75B ~S9□D200B	1.95

+ KEY SPEC

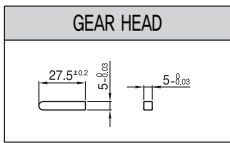

+ SPEC for output shaft of gearhead - (Table2)

MODEL	TYPES OF OUTPUT SHAF	MODEL	TYPES OF OUTPUT SHAF	MODEL	TYPES OF OUTPUT SHAF
S9SD3B ~S9SD200B	STRAIGHT TYPE	S9DD3B ~S9DD200B	D-CUT TYPE	S9KD3B ~S9KD200B	KEY TYPE

50Hz

MODEL	GEAR RATIO	3	3.6	5	6	7.5	9	10	12.5	15	18	20	25	30	36	40	50	60	75	90	100	120	150	180	200
	S9KD□B	rpm	500	416	300	250	200	166	150	120	100	83	75	60	50	41	37	30	25	20	16	15	12	10	8
	kg-cm	12.2	14.6	20.3	24.3	30.4	36.5	40.5	45.6	54.8	65.7	73.0	82.5	99.0	119	132	165	198	221	266	295	300	300	300	300
	N·m	1.196	1.431	1.989	2.381	2.989	3.577	3.969	4.469	5.370	6.439	7.154	8.085	9.702	11.66	12.94	16.17	19.40	21.67	26.09	28.93	29.42	29.42	29.42	29.42

60Hz

MODEL	GEAR RATIO	3	3.6	5	6	7.5	9	10	12.5	15	18	20	25	30	36	40	50	60	75	90	100	120	150	180	200
	S9KD□B	rpm	600	500	360	300	240	200	180	144	120	100	90	72	60	50	45	36	30	24	20	18	15	12	10
	kg-cm	9.72	11.7	16.2	19.4	24.3	29.2	32.4	36.5	43.8	52.6	58.4	66.0	79.2	95.0	106	132	158	177	212	236	283	300	300	300
	N·m	0.953	1.147	1.588	1.901	2.381	2.862	3.175	3.577	4.292	5.155	5.723	6.468	7.762	9.310	10.39	12.94	15.48	17.35	20.79	23.14	27.75	29.42	29.42	29.42

- ❖ The code in □ of gearhead model is for gear ratio.
- ❖ It is the permissible torque of the assembled motor and gearhead.
- ❖ The permissible torque of the motor and inter-decimal gearhead is 300 kg-cm.
- ❖ ■ color indicates that the output shaft of the geared motor rotates in the same direction as the output shaft of the motor. Others indicate rotation in the opposite direction.
- ❖ Rpm is based on synchronous speed (50Hz: 1500rpm, 60Hz: 1800rpm) divided by gear ratio. The actual rotation speed can be 2~20% less than displayed value depending on the load.
- ❖ Only "H" type is applicable. Please use "H" type motor.

SCHEMATIC DIAGRAMS

The direction of motor rotation is as viewed from the front shaft end of the motor.

